

# \*TB 9-6625-1965-24

DEPARTMENT OF THE ARMY TECHNICAL BULLETIN

## CALIBRATION PROCEDURE FOR DIGITAL MULTIMETER FLUKE, MODELS 8000A, 8000A-01, 8000A-05, 8000A/BU, 8000A/MAS, AND 8000A/MTR01

Headquarters, Department of the Army, Washington, DC  
15 January 2008

*Distribution Statement A: Approved for public release; distribution is unlimited.*

### REPORTING OF ERRORS AND RECOMMENDING IMPROVEMENTS

You can improve this manual. If you find any mistakes or if you know of a way to improve these procedures, please let us know. Mail your letter or DA Form 2028 (Recommended Changes to Publications and Blank Forms) directly to: Commander, U.S. Army Aviation and Missile Command, ATTN: AMSAM-MMC-MA-NP, Redstone Arsenal, AL 35898-5000. A reply will be furnished to you. You may also send in your comments electronically to our E-mail address: [2028@redstone.army.mil](mailto:2028@redstone.army.mil) or by fax 256-842-6546/DSN 788-6546. For the World Wide Web use: <https://amcom2028.redstone.army.mil>. Instructions for sending an electronic 2028 can be found at the back of this manual.

SECTION		Paragraph	Page
I.	IDENTIFICATION AND DESCRIPTION		
	Test instrument identification .....	1	2
	Forms, records, and reports .....	2	2
	Calibration description .....	3	2
II.	EQUIPMENT REQUIREMENTS		
	Equipment required .....	4	3
	Accessories required .....	5	3
III.	CALIBRATION PROCESS		
	Preliminary instructions .....	6	4
	Equipment setup .....	7	5
	Dc voltage accuracy and stability .....	8	6
	Ac voltage .....	9	6
	Dc current accuracy .....	10	7

\*This bulletin supersedes TB 9-6625-1965-35, dated 13 April 2004, including all changes.

	Paragraph	Page
Resistance (models 8000A, 8000A-01, 8000A-05, 8000A/BU and 8000A/MTR01 .....	11	8
Resistance (model 8000A/MAS option only) ...	12	8
Milliampere-second (model 8000A/MAS option only) .....	13	9
Final procedure .....	14	12

## SECTION I IDENTIFICATION AND DESCRIPTION

**1. Test Instrument Identification.** This bulletin provides instructions for the calibration of Digital Multimeter Fluke, Models 8000A, 8000A-01, 8000A-05, 8000A/BU, 8000A/MAS, and 8000A/MTR01. The manufacturers' manuals were used as the prime data sources in compiling these instructions. The equipment being calibrated will be referred to as the TI (test instrument) throughout this bulletin.

**a. Model Variations.** Model 8000A is the basic digital multimeter; model 8000A-01 has a battery pack option, 8000A-05 has a 10A current range option, model 8000A/MAS has a milliampere-second option, and model 8000A/MTR01 has an analog panel meter with battery pack option.

**b. Time and Technique.** The time required for this calibration is approximately 1 hour, using the dc and low frequency technique.

### 2. Forms, Records, and Reports

**a.** Forms, records, and reports required for calibration personnel at all levels are prescribed by TB 750-25.

**b.** Adjustments to be reported are designated (R) at the end of the sentence in which they appear. When adjustments are in tables, the (R) follows the designated adjustment. Report only those adjustments made and designated with (R).

**3. Calibration Description.** TI parameters and performance specifications which pertain to this calibration are in table 1.

Table 1. Calibration Description

Test instrument parameters	Performance specifications
Dc voltage	Range: 0 to $\pm 1200$ V in 5 ranges Accuracy: $\pm(0.1$ % of reading + 1 digit)
Ac voltage: Models 8000A, 8000A-01, 8000A-05, 8000A/BU and 8000A/MTR01	Range: 0 to 1200 V in 5 ranges Accuracy: 45 Hz to 10 kHz $\pm (0.5\%$ of reading + 2 digits) 10 kHz to 20 kHz $\pm (1.0\%$ of reading + 2 digits)
Model 8000A/MAS	Range: 0 to 1200 V in 5 ranges Accuracy: 45 Hz to 5 kHz $\pm(0.6\%$ of reading + 2 digits) 5 kHz to 10 kHz $\pm (1.0$ % of reading + 2 digits) 10 kHz to 20 kHz $\pm (2.0$ % of reading + 2 digits)

Table 1. Calibration Description - Continued

Test instrument parameters	Performance specifications
Dc current:  Model 8000A-05 (only) <sup>1</sup>	Range: 0 to 2000 mA in 5 ranges Accuracy: $\pm(0.3\%$ of reading + 1 digit)  Range: 10 A (< 1 minute operation from 10 A to 20 A @ 25 % duty cycle) Accuracy: $\pm(0.5\%$ of reading + 1 digit)
Ac current: <sup>2</sup>  Model 8000A-05 (only) <sup>1</sup>	Range: 0 to 2000 mA in 5 ranges Accuracy: 45 Hz to 10 kHz $\pm(1.0\%$ of reading + 2 digits) through 200 mA range 45 Hz to 3 kHz $\pm(1.0\%$ of reading + 2 digits) 2000 mA range  Range: 10 A (< 1 minute operation from 10 A to 20 A @ 25 % duty cycle) Accuracy: 45 Hz to 3 kHz $\pm(1.0\%$ of reading + 2 digits)
Resistance: Models 8000A,8000A-01, 8000A-05, 8000A/BU and 8000A/MTR01  Model 8000A/MAS	Range: 0 to 20 M $\Omega$ in 6 ranges $\pm(0.2\%$ of reading + 1 digit through 2000 k $\Omega$ ) $\pm(0.5\%$ of reading + 1 digit on 20 M $\Omega$ range)  Range: 0 to 2000 k $\Omega$ in 5 ranges Accuracy: $\pm(0.25\%$ of reading + 1 digit)
Milliampere-second Model 8000A/MAS only	Range: 0 to 2000 mA-seconds in 5 ranges Accuracy: $\pm(1.0\%$ of reading + 1 digit)

<sup>1</sup>Model 8000A-05 is functionally identical to the 8000A with an added 10 A current range.

<sup>2</sup>Ac current check is verified by dc current check.

## SECTION II EQUIPMENT REQUIREMENTS

**4. Equipment Required.** Table 2 identifies the specific equipment to be used in this calibration procedure. This equipment is issued with Secondary Transfer Calibration Standards Set AN/GSM-286, AN/GSM-287 and AN/GSM-705. Alternate items may be used by the calibrating activity. The items selected must be verified to perform satisfactorily prior to use and must bear evidence of current calibration. The equipment must meet or exceed the minimum use specifications listed in table 2. The accuracies listed in table 2 provide a four-to-one ratio between the standard and TI. Where the four-to-one ratio cannot be met, the actual accuracy of the equipment selected is shown in parenthesis.

**5. Accessories Required.** The accessories required for this calibration are common usage accessories, issued as indicated in paragraph 4 above, and are not listed in the calibration procedure.

Table 2. Minimum Specifications of Equipment Required

Common name	Minimum use specifications	Manufacturer and model (part number)
CALIBRATOR	Ac voltage: Range: 190 mV to 1000 V ac Accuracy: $\pm 0.157\%$ for 45 Hz to 10 kHz $\pm 0.273\%$ for 10 to 20 kHz Dc voltage: Range: 0 to 1000 V dc Accuracy: $\pm 0.039\%$ Dc current: Range: 0 to 2000 mA Accuracy: $\pm 0.092\%$ Range: 10A Accuracy: $\pm 0.15\%$ Resistance: Range: 0 to 20 M $\Omega$ Accuracy: $\pm 0.063\%$ , $\pm 0.138\%$ (20 M $\Omega$ range)	Fluke, Model 5720A (5700A) (p/o MIS-35947), w/amplifier, Fluke 5725A/AR (5725A/AR)
MULTIMETER	Range: -17 to 1 V dc	Fluke, Model 8840A/AF05 (AN/GSM-64D)
FREQUENCY COUNTER	Range: 0 to 2000 ms Accuracy: $\pm 5 \mu\text{s}$	Fluke, Model PM6681/656 (PM6681/656)

### SECTION III CALIBRATION PROCESS

#### 6. Preliminary Instructions

a. The instructions outlined in paragraphs 6 and 7 are preparatory to the calibration process. Personnel should become familiar with the entire bulletin before beginning the calibration.

b. Items of equipment used in this procedure are referenced within the text by common name as listed in table 2.

c. Unless otherwise specified, verify the result of each test and, whenever the test requirement is not met, take corrective action before continuing with the calibration. Adjustments required to calibrate the TI are included in this procedure. Additional maintenance information is contained in the manufacturers' manuals for this TI.

d. Unless otherwise specified, all controls and control settings refer to the TI.

7. Equipment Setup

**WARNING**

HIGH VOLTAGE is used or exposed during the performance of this calibration. DEATH ON CONTACT may result if personnel fail to observe safety precautions. REDUCE OUTPUT(S) to minimum after each step within the performance check where applicable.

- a. Remove TI protective cover as required for adjustments.
- b. Connect TI to a 115 V ac source.
- c. Press **POWER ON-OFF** switch to **ON** and allow at least 30 minutes for equipment to warm-up and stabilize.
- d. Press **FUNCTION DCV** and **RANGE 200 MV** pushbuttons.
- e. Short **V-Ω** and **COMMON** terminals. If TI does not indicate between 00.0 and 00.1, adjust R15 OFFSET (fig. 1) until TI indicates 00.0 (± sign flashing).
- f. Remove short.

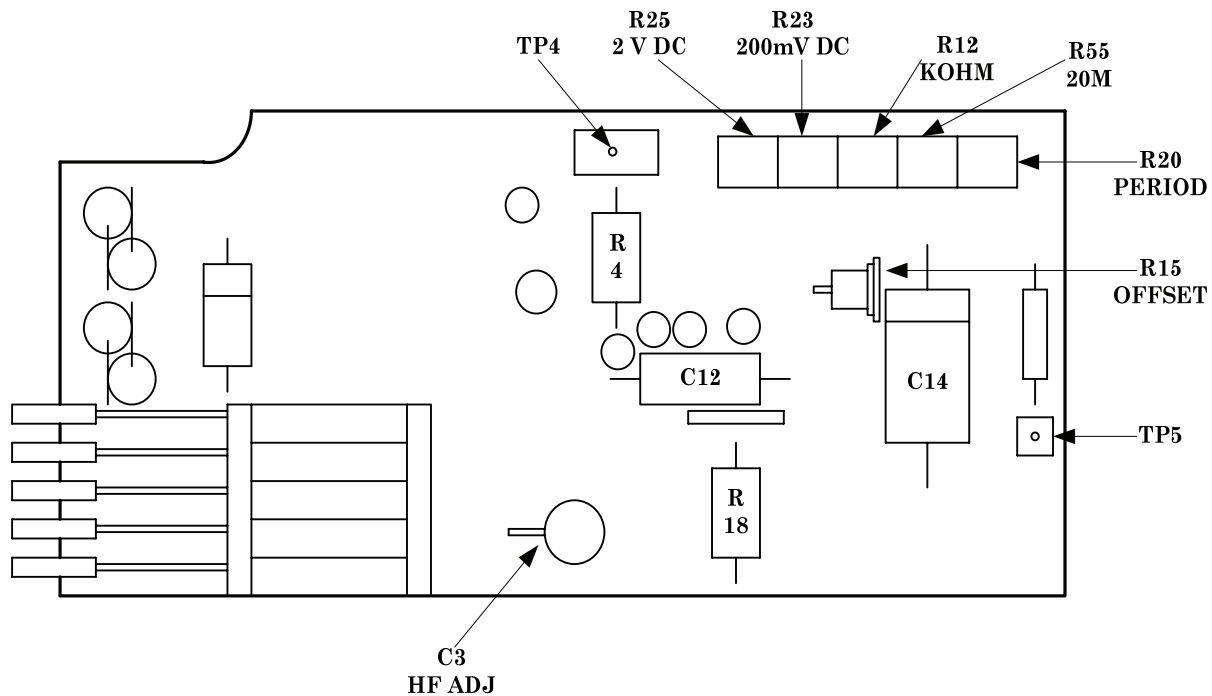

Figure 1. Model 8000A – top view.

## 8. Dc Voltage Accuracy and Stability

### a. Performance Check

(1) Connect TI **V-Ω** input to calibrator **OUTPUT HI** and TI **COMMON** input to calibrator **OUTPUT LO**.

(2) Set calibrator for an output amplitude of 190 mV dc. If TI does not indicate within limits specified in first row of table 3, perform **b** below.

(3) Repeat technique of (2) above using settings listed in table 3 below. If TI does not indicate within limits specified in table 3, perform **b** below.

Table 3. Dc Voltage

Calibrator	Test instrument		
	Range setting	Indication limits (V dc)	
		Min	Max
190 mV	200 mV	189.7	190.3
1.9 V	2 V	1.897	1.903
19 V	20 V	18.97	19.03
190 V	200 V	189.7	190.3
1000 V	1000 V	998	1002

### b. Adjustments

(1) Adjust calibrator for a 190 mV dc output. Adjust R23 200mV DC (fig. 1) until TI indicates 190.0 mV dc. Reverse leads and adjust R15 OFFSET (fig. 1) until TI indicates -190.0 mV dc(R).

(2) Adjust calibrator for a 1.9 V dc output. Adjust R25 2V DC (fig. 1) until TI indicates 1.900 V dc (R).

## 9. Ac Voltage

### a. Performance Check

(1) Press **FUNCTION ACV** and **RANGE 20** pushbuttons.

(2) Set calibrator for an output amplitude of 19 V and an output frequency of 20 kHz. If TI does not indicate within limits specified in first row of table 4, perform **b** below.

(3) Repeat technique of (1) and (2) above, for settings and indications listed in table 4. TI will indicate within limits specified in table 4.

Table 4. Ac Voltage

Calibrator		Test instrument		
Output amplitude	Output frequency	Range	Indication limits <sup>1</sup>	
			Min	Max
19 V	20 kHz	20 V	18.79 V (18.60 V)	19.21 V (19.40 V)
190 mV	45 Hz	200 mV	188.8 mV (188.7 mV)	191.2 mV (191.3 mV)
190 mV	9 kHz	200 mV	188.8 mV (187.9 mV)	191.2 mV (192.1 mV)
190 mV	20 kHz	200 mV	187.9 mV (186.0 mV)	192.1 mV (194.0 mV)
1.9 V	45 Hz	2 V	1.888 V (1.887 V)	1.912 V (1.913 V)

See footnote at end of table.

Table 4. Ac Voltage - Continued

Calibrator		Test instrument		
Output amplitude	Output frequency	Range	Indication limits <sup>1</sup>	
			Min	Max
1.9 V	9 kHz	2 V	1.888 V (1.879 V)	1.912 V (1.921 V)
1.9 V	20 kHz	2 V	1.879 V (1.860 V)	1.921 V (1.940 V)
19 V	45 Hz	20 V	18.88 V (18.87 V)	19.12 V (19.13 V)
19 V	9 kHz	20 V	18.88 V (18.79 V)	19.12 V (19.21 V)
190 V	45 Hz	200 V	188.8 V (188.7 V)	191.2 V (191.3 V)
190 V	9 kHz	200 V	188.8 V (187.9 V)	191.2 V (192.1 V)
190 V	20 kHz	200 V	187.9 V (186.0 V)	192.1 V (194.0 V)
1000 V	45 Hz	1200 V	993 V (992 V)	1007 V (1008 V)
1000 V	9 kHz	1200 V	993 V (988 V)	1007 V (1012 V)
500 V	20 kHz	1200 V	493 V (488 V)	507 V (512 V)

<sup>1</sup> Indication in parenthesis for model 8000A/MAS.

**b. Adjustments.** Adjust calibrator output voltage to 19 V ac @ 20 kHz. Adjust C3 HF ADJ (fig. 1) until TI indicates 19.00 V ac (R).

## 10. Dc Current Accuracy

### a. Performance Check

- (1) Connect TI MA input to calibrator **OUTPUT HI** and TI COMMON input to calibrator **OUTPUT LO**.
- (2) Press **FUNCTION DC MA** and **RANGE 200  $\mu$ A** pushbuttons.
- (3) Set calibrator to 190  $\mu$ A. TI will indicate within limits specified in first row of table 5.
- (4) Repeat technique of (2) and (3) above using settings listed in table 5. TI will indicate within limits specified in table 5.

Table 5. Dc Current

Calibrator	Range setting	Test instrument	
		Indication limits	
Output		Min	Max
190 $\mu$ A	200 $\mu$ A	189.3 $\mu$ A	190.7 $\mu$ A
1.9 mA	2 mA	1.893 mA	1.907 mA
19 mA	20 mA	18.93 mA	19.07 mA
190 mA	200 mA	189.3 mA	190.7 mA
1900 mA	2000 mA	1893 mA	1907 mA
10 A <sup>1</sup>	20 A	9.94 A	10.06 A

<sup>1</sup> For model 8000A-05 only.

**b. Adjustments.** No adjustments can be made.

## 11. Resistance (Models 8000A, 8000A-01, 8000A-05, 8000A/BU and 8000A/MTR01)

### a. Performance Check

- (1) Connect TI **V- $\Omega$**  input to calibrator **OUTPUT HI** and TI COMMON input to calibrator **OUTPUT LO**.

- (2) Press TI **FUNCTION kΩ** and **RANGE 200 Ω** pushbuttons.
- (3) Set calibrator for a 190 Ω nominal output.
- (4) Rotate calibrator knob below **EDIT FIELD** pushbutton to adjust calibrator display indication to equal TI indication. If calibrator **err** display does not indicate within limits specified in first row of table 6, perform **b** below.
- (5) Repeat technique of (2) through (4) above, using calibrator outputs and TI indications listed in table 6. If calibrator **err** display does not indicate within limits specified in table 6, perform **b** below.

Table 6. Resistance

Test instrument	Calibrator	
<b>RANGE</b> pushbutton settings	Nominal output	<b>err</b> display indication ±(%)
200 Ω	190 Ω	0.253
2 kΩ	1.9 kΩ	0.253
20 kΩ	19 kΩ	0.253
200 kΩ	190 kΩ	0.253
2000 kΩ	1900 kΩ	0.253
20 MΩ	19 MΩ	0.553

**b. Adjustments**

- (1) Set calibrator for 19.00 MΩ. Adjust R55 20M (fig. 1) until TI indicates actual resistance of calibrator (R).
- (2) Adjust calibrator for 19.00 kΩ. Adjust R12 KOHM (fig. 1) until TI indicates actual resistance of calibrator (R).

**12. Resistance (Model 8000A/MAS Option Only)**

**a. Performance Check**

- (1) Connect TI **V-Ω** input to calibrator **OUTPUT HI** and TI **COMMON** input to calibrator **OUTPUT LO**.
- (2) Press TI **FUNCTION kΩ** and **RANGE 200 Ω** pushbuttons.
- (3) Set calibrator for a 190 Ω nominal output.
- (4) Rotate calibrator knob below **EDIT FIELD** pushbutton to adjust calibrator display indication to equal TI indication. If calibrator **err** display does not indicate within limits specified in first row of table 7, perform **b** below.
- (5) Repeat technique of (2) through (4) above, using calibrator outputs and TI indications listed in table 7. If calibrator **err** display does not indicate within limits specified in table 7, perform **b** below.



Table 7. Resistance

Test instrument	Calibrator		
RANGE pushbutton settings	Nominal output	err display indication ±(%)	
200 Ω	190.0 Ω	0.303	
2 k Ω	1.900 k Ω	0.303	
20 k Ω	19.00 k Ω	0.303	
200 kΩ	190 kΩ	0.303	
2000 k Ω	1900 k Ω	0.303	



### b. Adjustments

(1) Set calibrator for 190 kΩ. Adjust R12 KOHM (fig. 1) until TI indicates actual resistance of calibrator (R).

(2) Set calibrator for 1.9 kΩ. Adjust R1 (fig. 2) until TI indicates actual resistance of calibrator (R).

## 13. Milliampere-second (Model 8000A/MAS Option Only)

### a. Performance Check

- (1) Position controls as listed in (a) through (c) below:
  - (a) Press **FUNCTION DC MA** pushbutton.
  - (b) Press **RANGE 200** pushbutton.
  - (c) **READ mASEC-ERASE** to **ERASE**.
- (2) Using cables of equal length connect calibrator output to **TI MA** and **COMMON** inputs and to frequency counter **A** input.
- (3) Set **TI mASEC mA** switch to **mA**.
- (4) Set calibrator for an initial 100 mA output and rotate calibrator knob below **EDIT FIELD** pushbutton to adjust calibrator for a TI indication of 100 mA.
- (5) Set calibrator to **STANDBY**.
- (6) Position frequency counter controls as listed in (a) through (i) below:
  - (a) **FUNCTION** to **TIME A-B**.
  - (b) **INPUT A** slope to  (positive).
  - (c) **INPUT B** slope to  (negative).
  - (d) **INPUT A 1X/10X** to **1X**.
  - (e) **INPUT B** to **COM A**.
  - (f) **INPUT A AC/DC** to **DC**.
  - (g) **INPUT A 50Ω/1MΩ** to **50Ω**.
  - (h) **INPUT B 50Ω/1MΩ** to **50Ω**.
  - (i) **MEASUREMENT TIME** to **80 ns**.
- (7) Set calibrator to **OPERATE** and adjust frequency counter **TRIGGER LEVEL SET A** to start count (approximately 2.5 V).

(8) Adjust frequency counter **TRIGGER LEVEL SET B** to stop count (approximately 2.5 V).

(9) Repeat (7) and (8) above as necessary until frequency counter starts when calibrator is in **OPERATE**; stops when calibrator is in **STANDBY**, and **A** and **B TRIG** indicator lights are blinking in unison when calibrator is in **OPERATE**. Leave calibrator in **STANDBY** after establishing trigger level.

(10) Set **mASEC mA** switch to **mASEC** and **READ mASEC-ERASE** switch to **ERASE**.

**NOTE**

In the following steps do not leave calibrator in **OPERATE** for more than 1 second as monitored on frequency counter.

(11) Momentarily set calibrator to **OPERATE**. TI will indicate  $00.0 \pm 0.1$  mASEC; if not, perform **b** (1) through (4) below.

(12) Set **READ mASEC-ERASE** switch to **READ mASEC**.

(13) Momentarily set calibrator to **OPERATE**. If TI does not indicate same reading in mASEC as frequency counter indicates in time,  $\pm 2$  digits, perform **b** (5) through (16) below.

(14) Press TI **RANGE 2000MA** pushbutton and repeat steps **12 a** (3), (4), (5), (9), and (10) above.

(15) Momentarily set calibrator to **OPERATE**. TI will indicate  $000 \pm 1$  mASEC.

(16) Set **READ mASEC-ERASE** switch to **READ mASEC**.

(17) Momentarily set calibrator to **OPERATE**. TI will indicate the same reading in mA as frequency counter indicates in time,  $\pm 2$  digits.

**b. Adjustments**

(1) Disconnect TI from equipment setup.

(2) Set **READ mASEC-ERASE** switch to **ERASE**.

(3) Set **mASEC mA** switch to **mASEC**. If TI does not indicate 0000,  $\pm 1$  digit, adjust R14 **ZERO** (fig. 2) until TI indicates 0000.

(4) Using cables of equal length connect calibrator output to TI **MA** and **COMMON** inputs and to frequency counter **A** input.

(5) Set **mASEC mA** switch to **mA**.

(6) Set calibrator for an initial 22 mA output and, if necessary, rotate calibrator knob below **EDIT FIELD** pushbutton to adjust calibrator for a TI indication of 22 mA.

(7) Set calibrator to **STANDBY**.

(8) Connect digital multimeter to TI TP3 (fig. 2) and **COMMON** terminal.

(9) Set **mASEC mA** switch to **mASEC**.

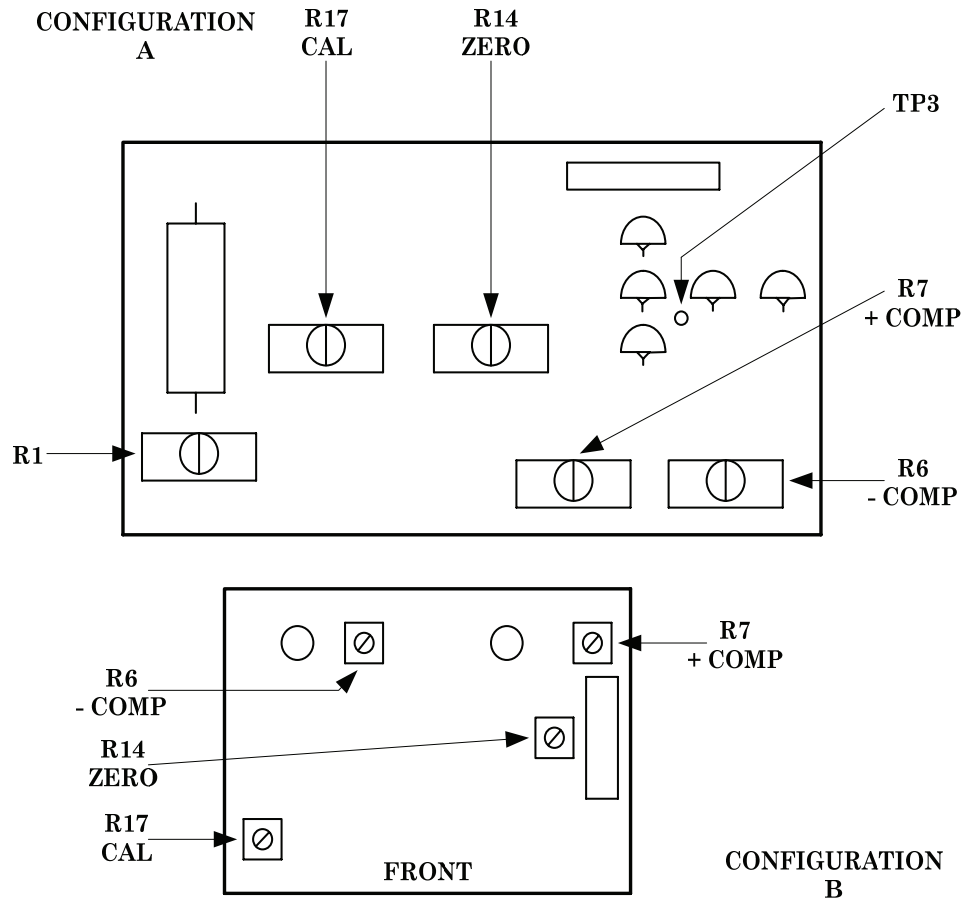

Figure 2. Model 8000A/MAS - top view.

(10) Momentarily set calibrator to **OPERATE**. If digital multimeter does not indicate less than 1 V dc with +22 mA applied to TI, adjust R7 +COMP (fig. 2) until digital multimeter indicates less than 1 V dc.

(11) Set **mA SEC mA** switch to **mA**.

(12) Set calibrator for an initial 17 mA output and, if necessary, rotate calibrator knob below **EDIT FIELD** pushbutton to adjust calibrator for a TI indication of 17 mA.

(13) Set calibrator to **STANDBY** and set **mA SEC mA** switch to **mA SEC**.

(14) Momentarily set calibrator to **OPERATE**. If digital multimeter does not indicate between -13 and -17 V dc, adjust R7 +COMP (fig. 2) until digital multimeter does indicate between -13 and -17 V dc.

(15) Set calibrator to **STANDBY**, reverse leads on calibrator and repeat (5) through (14) above. If digital multimeter does not indicate less than 1 V dc when -22 mA is applied and between -13 and -17 V dc when -17 mA is applied to TI, adjust R6 -COMP (fig. 2) until both indications are obtained.

(16) Repeat **a** above. If TI is out of tolerance at **a** (15) above, adjust R17 CAL (fig. 2) while toggling calibrator between **OPERATE** and **STANDBY** until TI indicates the same reading in mA as frequency counter indicates in time,  $\pm 2$  digits (R).

**14. Final Procedure**

- a.** Deenergize and disconnect all equipment.
- b.** Annotate and affix DA label/form in accordance with TB 750-25.

By Order of the Secretary of the Army:

Official:



JOYCE E. MORROW  
*Administrative Assistant to the  
Secretary of the Army*

0733202

GEORGE W. CASEY, JR.  
*General, United States Army  
Chief of Staff*

Distribution:

To be distributed in accordance with the initial distribution number (IDN) 342159, requirements for calibration procedure TB 9-6625-1965-24.



### Instructions for Submitting an Electronic 2028

The following format must be used if submitting an electronic 2028. The subject line must be exactly the same and all fields must be included; however, only the following fields are mandatory: 1, 3, 4, 5, 6, 7, 8, 9, 10, 13, 15, 16, 17, and 27.

From: "Whomever" [whomever@redstone.army.mil](mailto:whomever@redstone.army.mil)

To: <2028@redstone.army.mil

Subject: DA Form 2028

1. **From:** Joe Smith
2. **Unit:** home
3. **Address:** 4300 Park
4. **City:** Hometown
5. **St:** MO
6. **Zip:** 77777
7. **Date Sent:** 19-OCT-93
8. **Pub no:** 55-2840-229-23
9. **Pub Title:** TM
10. **Publication Date:** 04-JUL-85
11. **Change Number:** 7
12. **Submitter Rank:** MSG
13. **Submitter FName:** Joe
14. **Submitter MName:** T
15. **Submitter LName:** Smith
16. **Submitter Phone:** 123-123-1234
17. **Problem:** 1
18. **Page:** 2
19. **Paragraph:** 3
20. **Line:** 4
21. **NSN:** 5
22. **Reference:** 6
23. **Figure:** 7
24. **Table:** 8
25. **Item:** 9
26. **Total:** 123
27. **Text**

This is the text for the problem below line 27.







